

No. OF POSITION	A	B	C	D	E	F	G
10	5.00	6.70	13.00	3.20	6.40	1.00	16.00
20	9.00	10.70	17.00	7.20	10.40	5.00	20.00
30	13.00	14.70	21.00	11.20	14.40	9.00	24.00
40	17.00	18.70	25.00	15.20	18.40	13.00	28.00
50	21.00	22.70	29.00	19.20	22.40	17.00	32.00
60	25.00	26.70	33.00	23.20	26.40	21.00	36.00
70	29.00	30.70	37.00	27.20	30.40	25.00	40.00
80	33.00	34.70	41.00	31.20	34.40	29.00	44.00
90	37.00	38.70	45.00	35.20	38.40	33.00	48.00
100	41.00	42.70	49.00	39.20	42.40	37.00	52.00

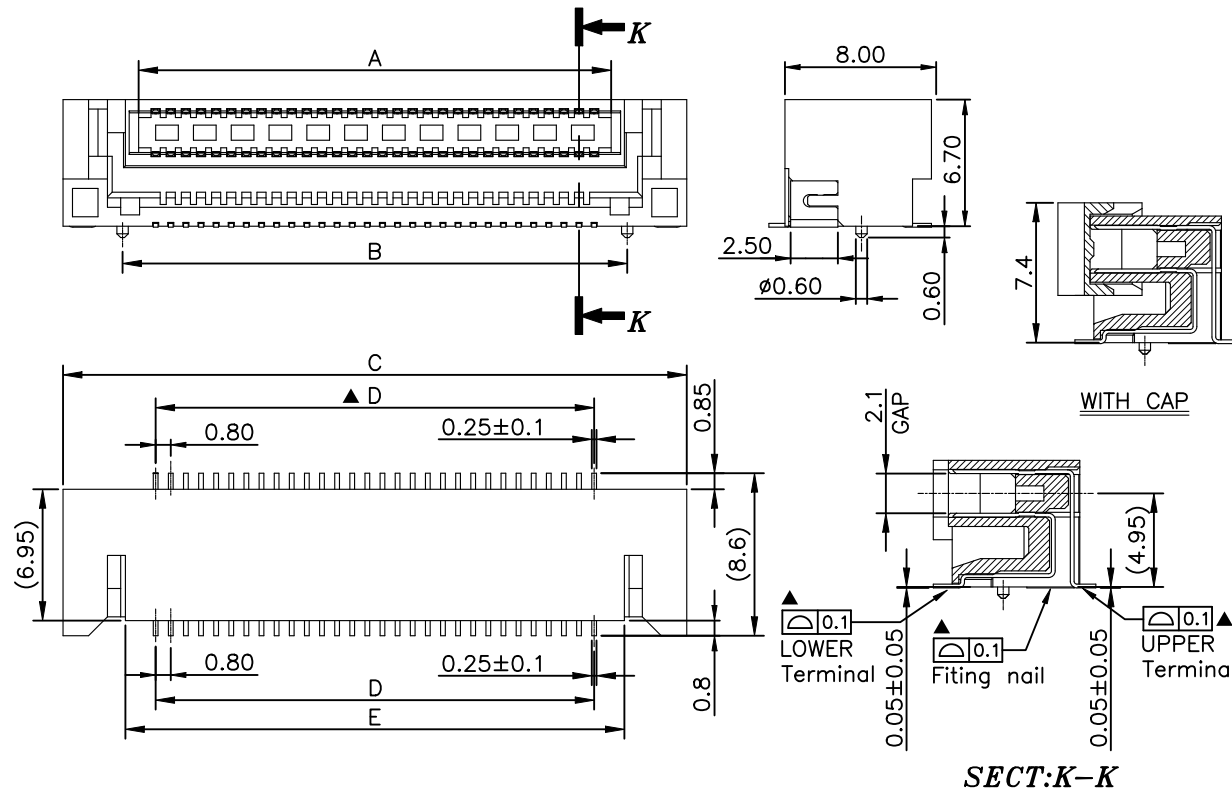

- Notes:
- Housing material: PA-9T (UL94V-0).
 - CAP material: PA-6T (UL94V-0).
 - Terminal material: phosphor bronze.
The overall 60u"~200u" Nickel Plated (lead-free).
Welding pin gold plated 2u"~8u" MIN.
contact point gold plated 4u" MIN. (Pb free).
 - Fitting nail material: brass.
The overall 50u"~100u" Nickel Plated (lead-free).
Plated with matte Tin(100%) 80u"~150u" (lead-free).
 - "▲" Important dimensions.
 - PART NO. Specifications: 123004-20XX50

Number of positions

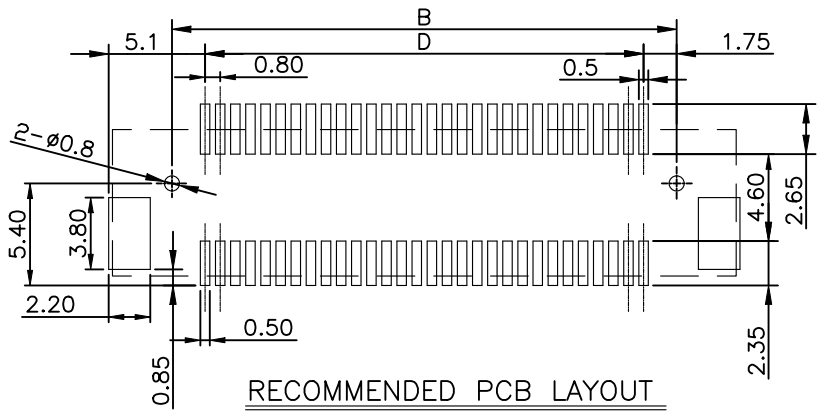

RECOMMENDED PCB LAYOUT
GENERAL TOLERANCE: ±0.05
(MOUNTING SIDE)

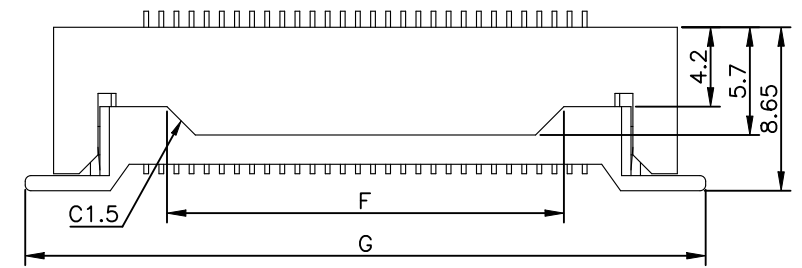
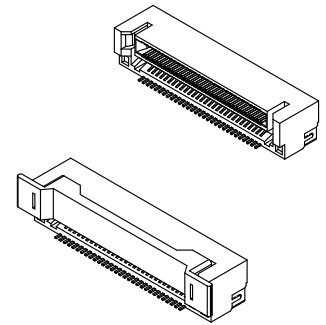

WITH CAP

				UNLESS OTHERWISE SPECIFIED TOLERANCES ARE	客户图 Drawings	北极大电子科技有限公司 BEIJIDA ELECTRONICS TECHNOLOGY CO. LIMITED			
				X. ±0.20	APPROVED	DATE	COMPUTER NO		
				X.X ±0.10	陈天舒	2017-12-19	123004-20XX50		
				X.XX ±0.10	CHECKED	DATE	NAME		
				X.XXX ±0.30'	陈天舒	2017-12-19	BTB0.8-5 SERIES Floating PLUG ASSY 90°		
▲	Revision of plating specification	Lu	2020-05-20	UNIT	DRAWN	DATE	SIZE	SCALE	REV
	Release of drawing	Lu	2017-12-19	MM	张运兴	2017-12-19	A4	2.5:1	B
SER	REVISIONS	CHK	DATE						