

- HOUSING MATERIAL: HEAT RESISTANT PLASTIC UL94 V-0.
- ACTUATOR MATERIAL: HEAT RESISTANT PLASTIC UL94 V-0.
- TERMINAL MATERIAL: PHOSPHOR BRONZE.
 1. PLATED WITH BRIGHT TIN(100%) 80 μ "~150 μ "
 2. PLATED WITH MATTE TIN(100%) 80 μ "~150 μ "
 3. PLATED WITH GOLD MORE THAN 1 μ .
- FITTING NAIL MATERIAL: BRASS.
 1. PLATED WITH BRIGHT TIN(100%) 80 μ "~150 μ "
 2. PLATED WITH MATTE TIN(100%) 80 μ "~150 μ "
- PART NO. SPECIFICATION: 101026-X0XXX0-HF

- | | |
|------|---------------|
| 1:管装 | 1:雾锡 |
| 2:卷装 | 2:亮锡 |
| 3:袋装 | 3:镀金1 μ ' |
| 4:其他 | 5:镀金3 μ ' |
| | 6:半金锡 |

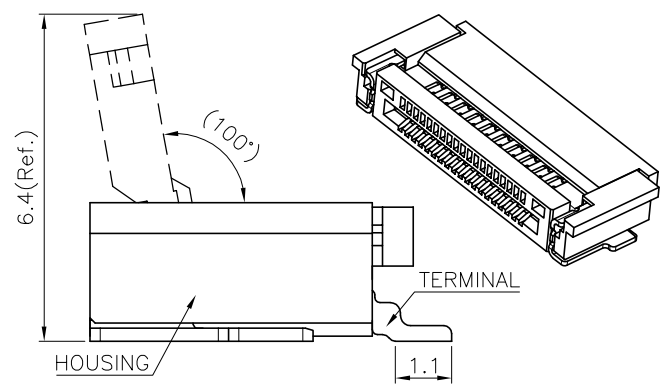

NO. of Contacts(n)	Dimensions				
	A	B	C	D	E
4	10.50	8.40	3.00	5.05	10.65
5	11.50	9.40	4.00	6.05	11.65
6	12.50	10.40	5.00	7.05	12.65
7	13.50	11.40	6.00	8.05	13.65
8	14.50	12.40	7.00	9.05	14.65
9	15.50	13.40	8.00	10.05	15.65
10	16.50	14.40	9.00	11.05	16.65
11	17.50	15.40	10.00	12.05	17.65
12	18.50	16.40	11.00	13.05	18.65
13	19.50	17.40	12.00	14.05	19.65
14	20.50	18.40	13.00	15.05	20.65
15	21.50	19.40	14.00	16.05	21.65
16	22.50	20.40	15.00	17.05	22.65
17	23.50	21.40	16.00	18.05	23.65
18	24.50	22.40	17.00	19.05	24.65
19	25.50	23.40	18.00	20.05	25.65
20	26.50	24.40	19.00	21.05	26.65
21	27.50	25.40	20.00	22.05	27.65
22	28.50	26.40	21.00	23.05	28.65
23	29.50	27.40	22.00	24.05	29.65
24	30.50	28.40	23.00	25.05	30.65
25	31.50	29.40	24.00	26.05	31.65
26	32.50	30.40	25.00	27.05	32.65
27	33.50	31.40	26.00	28.05	33.65
28	34.50	32.40	27.00	29.05	34.65
29	35.50	33.40	28.00	30.05	35.65
30	36.50	34.40	29.00	31.05	36.65

UNLESS OTHERWISE SPECIFIED TOLERANCES ARE			
X.			
X.X			± 0.1
X.XX			± 0.05
X.XXX			
ANG.			$\pm 0^{\circ}30'$
REVISIONS	CHK	DATE	UNIT
SER			MM

客户图 Drawings		北极大电子科技有限公司 BEIJIDA ELECTRONICS TECHNOLOGY CO. LIMITED		
APPROVED	DATE	COMPUTER NO		
CHECKED	DATE	NAME		
DRAWN	DATE	SIZE	SCALE	REV

张运兴 2012-05-24 A4 7:1 C



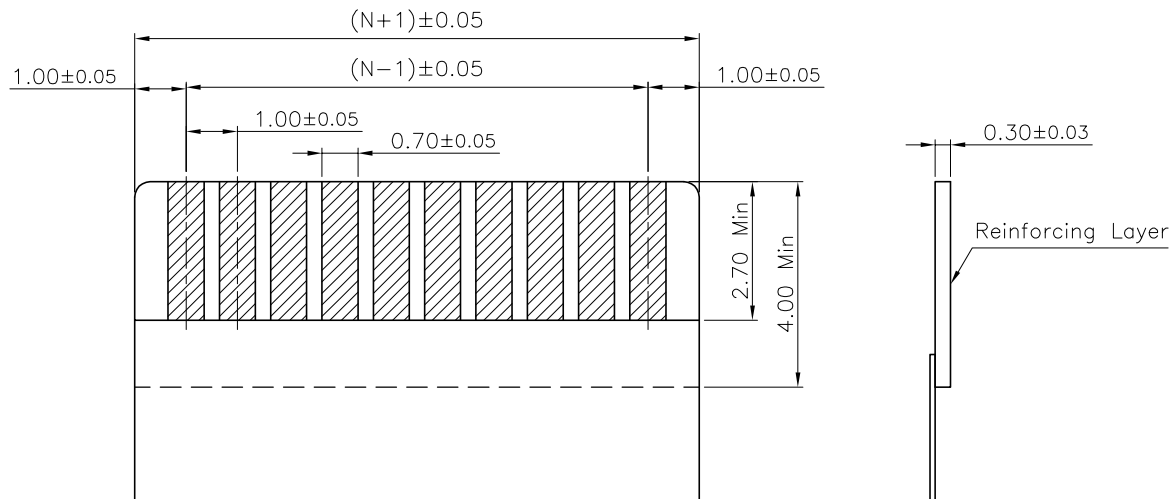

RECOMMENDED FFC/FPC DIMENSION

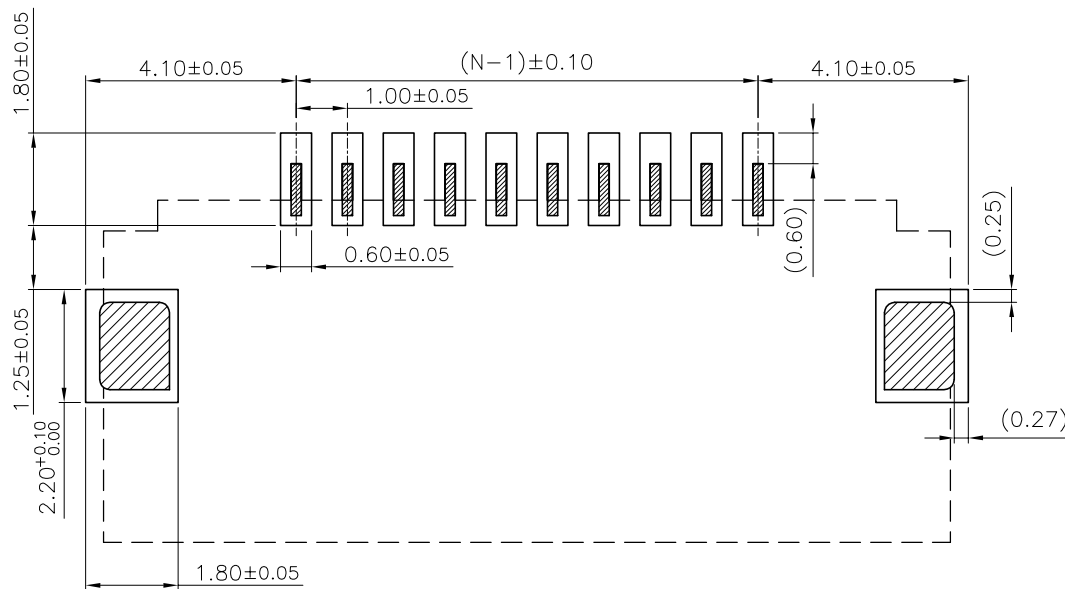

PCB LAYOUT



SER	REVISIONS	CHK	DATE
	增加无卤标识	张运兴	2015-12-07
	修改内腔尺寸	陈天舒	2014-12-27

UNLESS OTHERWISE SPECIFIED TOLERANCES ARE	
X.	
X.X	±0.1
X.XX	±0.05
X.XXX	
ANG.	±0°30'

客户图 Drawings	
APPROVED	DATE
CHECKED	DATE
DRAWN	DATE

客户图 Drawings			北极大电子科技有限公司 BEIJIDA ELECTRONICS TECHNOLOGY CO. LIMITED		
APPROVED	DATE	COMPUTER NO	101026-X0XXX0-HF		
CHECKED	DATE	NAME	FPC1.0-7代H2.7后掀式(2/2)		
DRAWN	DATE	SIZE	SCALE	REV	
张运兴	2012-05-24	A4	7:1	C	